

Connect with us on:



SAVE 15% ON ALL ITEMS

ELECTRONIC CALIPERS (STANDARD TYPE, NON-WATERPROOF)

ELECTRONIC WATERPROOF CALIPERS



1108-150

INSIZE
ISO17025 CERTIFICATE
AVAILABLE AT
EXTRA CHARGE
(REFER TO BACK COVER)

**INSPECTION
CERTIFICATE**
TRACEABLE TO NIST

**DATA
OUTPUT**

- Resolution .0005"/0.01mm
- Buttons: on/off, zero, inch/mm
- Automatic power off, move the digital unit to turn on power
- Battery CR2032, data output
- Made of stainless steel
- Optional accessory: data output cable

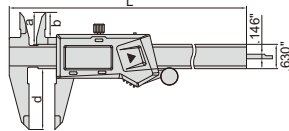

Part No.	Range	Accuracy	L	a	b	d	List Price (\$)	Sale Price (\$)
1108-150*	0-6"/0-150mm	±.0010"	9.291"	.827"	.630"	1.575"	63.10	53.6
1108-200*	0-8"/0-200mm	±.0015"	11.260"	.945"	.748"	1.969"	93.30	79.3
1108-300*	0-12"/0-300mm	±.0015"	15.748"	.984"	.807"	2.362"	141.00	120

*Supplied with manufacturer inspection certificate traceable to NIST



1118-150B

ATTENTION: IT IS NECESSARY TO SET ZERO AFTER POWER ON EACH TIME

**IP67
WATERPROOF**

ATTENTION: NO DATA OUTPUT

**INSPECTION
CERTIFICATE**
TRACEABLE TO NIST

- Accuracy ±.0015"
- IP67 dust/waterproof
- Resolution .0005"/0.01mm
- Button function: zero, on/off, inch/mm, ABS/REL, hold
- Battery CR2032
- Made of stainless steel

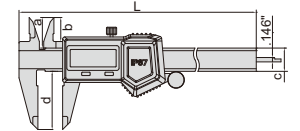

Part No.	Range	L	a	b	c	d	List Price (\$)	Sale Price (\$)
1118-150B*	0-6"/0-150mm	9.291"	.827"	.630"	.630"	1.575"	193.00	164.00
1118-200B*	0-8"/0-200mm	11.260"	.945"	.748"	.630"	1.969"	295.00	251.00
1118-300B*	0-12"/0-300mm	15.748"	.984"	.807"	.669"	2.362"	353.00	300.00

*Supplied with manufacturer inspection certificate traceable to NIST

DIAL CALIPERS

- Shockproof dial indicator
- Made of stainless steel



1311-6

**INSPECTION
CERTIFICATE**
TRACEABLE TO NIST

**SHOCK
PROOF**

INSIZE
ISO17025 CERTIFICATE
AVAILABLE AT
EXTRA CHARGE
(REFER TO BACK COVER)

Dial indicator graduation .001"

Part No.	Range	Accuracy	L	a	b	c	d	D	t	List Price (\$)	Sale Price (\$)
1311-6*	0-6"	±.0015"	9.252"	.827"	.650"	.630"	1.575"	1.535" DIA	.256"	62.90	53.50
1311-8*	0-8"	±.0020"	11.339"	.945"	.748"	.630"	1.890"	1.535" DIA	.256"	83.50	71.00
1311-12*	0-12"	±.0020"	16.142"	1.102"	.866"	.787"	2.441"	1.752" DIA	.295"	147.00	125.00

*Supplied with manufacturer inspection certificate traceable to NIST

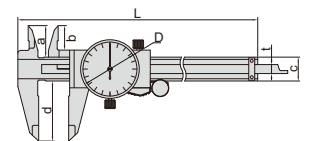

ELECTRONIC CALIPER WITH INTERCHANGEABLE POINTS (NON-WATERPROOF) PART NO. 1526-200



1526-200

**DATA
OUTPUT**

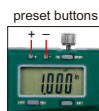

- Supplied with 3 pairs of points and zero setting block for external measurement
- Resolution .0005"/0.01mm
- Buttons: on/off, set, inch/mm, preset (+, -)
- Automatic power off, move the digital unit to turn on power
- Battery CR2032, data output
- Made of stainless steel
- Optional accessory: points, depth stop, data output cable

depth stop 6143
(optional)

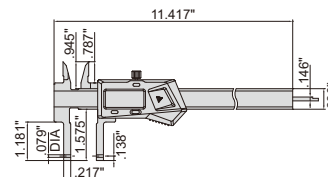

Part No.	List Price (\$)	Sale Price (\$)
1526-200	426.00	362.00

short spherical points (included)



long spherical/flat points (included)



spherical blade points (included)

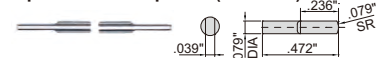

Point	Range	Accuracy	Application
short spherical points	.5-8.5"/12-212mm (internal)	±.0015"	for grooves inside small hole
long spherical/flat points	1-8.8"/24-224mm (internal) 0-7.5"/0-187mm (external)	±.0015"	spherical points for grooves inside hole flat points for external grooves
spherical blade points	1-8.8"/24-224mm (internal) 0-7.5"/0-187mm (external)	±.0015"	for narrow grooves inside hole

DEPTH BASE ATTACHMENT

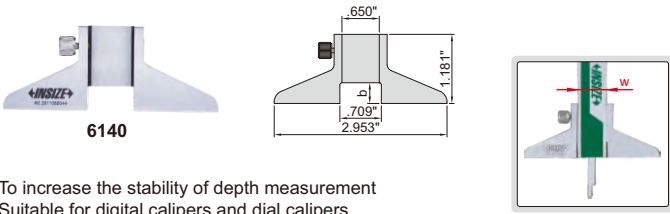

- To increase the stability of depth measurement
- Suitable for digital calipers and dial calipers
- Made of stainless steel

Part No.	Application	b	List Price (\$)	Sale Price (\$)
6140	suitable for calipers with beam width (w) .630"	.354"	23.60	20.10

ELECTRONIC HEIGHT GAGE WITH DRIVING WHEEL (NON-WATERPROOF)

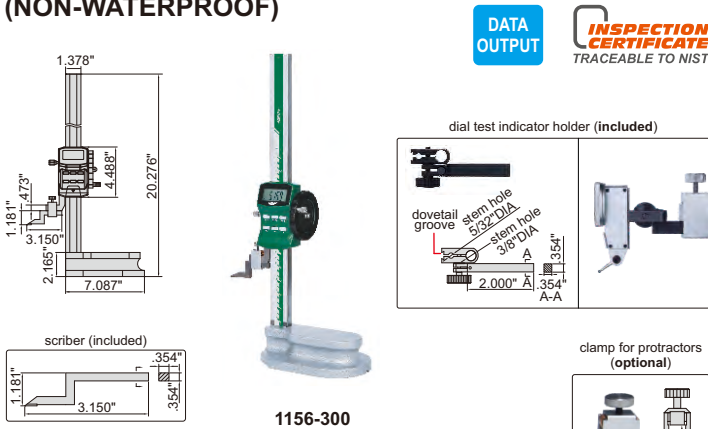

- Resolution .0005"/0.01mm
- Buttons: on/off, zero, inch/mm, preset (+, -), hold
- Automatic power off, move the digital unit to turn on power
- Carbide tipped scriber
- Made of stainless steel
- Battery CR2032, data output
- Supplied with dust cover
- With dial test indicator holder
- Optional accessory: data output cable, clamp for protractors (part no. 2372-CLAMP)

Part No.	Range	Accuracy	List Price (\$)	Sale Price (\$)
1156-300*	0-12"/0-300mm	±.0015"	615.00	523.00

*Supplied with manufacturer inspection certificate traceable to NIST

ELECTRONIC DEPTH GAGE WITH MOUNTING HOLES FOR EXTENSION BASE(NON-WATERPROOF)



- Resolution .0005"/0.01mm
- Buttons: on/off, zero, inch/mm
- Automatic power off, move the digital unit to turn on power
- Battery CR2032, data output
- Made of stainless steel
- Optional accessory: data output cable, extension base

Part No.	Range	Accuracy	List Price (\$)	Sale Price (\$)
1147-200	0-8"/0-200mm	±.0015"	180.00	153.00

ELECTRONIC OUTSIDE MICROMETER (BASIC TYPE, WITHOUT DATA OUTPUT)



- Resolution .00005"/0.001mm
- Button functions: on/off, set, inch/mm, ABS/INC
- No data output, friction thimble
- LR44 battery, automatic power off
- Carbide measuring faces
- Supplied with spherical anvil

Part No.	Range	Accuracy	List Price (\$)	Sale Price (\$)
3109-25E*	0-1"/0-25mm	±.00010"	116.00	98.60

*Supplied with manufacturer inspection certificate traceable to NIST

OUTSIDE MICROMETERS

- Graduation .0001"
- Carbide measuring faces
- Ratchet stop type
- Supplied with setting standards (except 0-1")

Part No.	Range	Accuracy	L	a	b	List Price (\$)	Sale Price (\$)
3203-1A*	0-1"	.00015"	1.260"	.354"	1.102"	40.40	34.30
3203-2A*	1-2"	.00015"	2.244"	.551"	1.496"	45.10	38.30
3203-3A*	2-3"	.00020"	3.228"	.591"	1.929"	50.20	42.70
3203-4A*	3-4"	.00020"	4.213"	.591"	2.362"	56.50	48.00

Part No.	Range	Micrometers included	Packaging	List Price (\$)	Sale Price (\$)
3203-33A*	0-3"	3203-1A, 3203-2A, 3203-3A	blow mould case	119.00	101.00
3203-44A*	0-4"	3203-1A, 3203-2A, 3203-3A, 3203-4A	blow mould case	175.00	149.00
3203-66A*	0-6"	3203-1A, 3203-2A, 3203-3A, 3203-4A, 3203-5A, 3203-6A	blow mould case	309.00	263.00

*Supplied with manufacturer inspection certificate traceable to NIST

PISTOL GRIP THREE POINT BORE GAGES

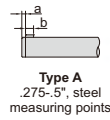
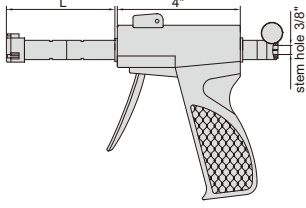

Type A
.275-.5", steel measuring points



electronic indicator is optional

2124-E035

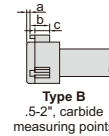

Type B
.5-2", carbide measuring points



electronic indicator is optional

2124-E1

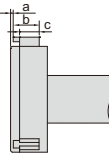

Type C
2-4", carbide measuring points



electronic indicator is optional

2124-E4

- Optional accessory: digital indicators (part no. 2108-101EF, resolution .00005"/0.001mm)



Individual

Part No.	Range	Type	Accuracy	Setting ring (included)	Extension rod (included)	L	a	b	c	List Price (\$)	Sale Price (\$)
2124-E035 *	.275-.35"	A	.00015"	.275" DIA	4"	2"	.059"	.098"	—	551.00	468.00
2124-E0425 *	.35-.425"	A	.00015"	.35" DIA	4"	2"	.059"	.098"	—	540.00	459.00
2124-E05 *	.425-.5"	A	.00015"	.5" DIA	4"	2"	.059"	.098"	—	573.00	487.00
2124-E065 *	.5-.65"	B	.00015"	.65" DIA	6"	2.6"	.020"	.236"	.177"	579.00	492.00
2124-E08 *	.65-.8"	B	.00015"	.65" DIA	6"	2.6"	.020"	.236"	.177"	614.00	522.00
2124-E1 *	.8-1"	B	.00015"	1" DIA	6"	3.64"	.020"	.315"	.236"	654.00	556.00
2124-E112 *	1-1.2"	B	.00015"	1" DIA	6"	3.64"	.020"	.315"	.236"	697.00	592.00
2124-E16 *	1.2-1.6"	B	.00015"	1.6" DIA	6"	3.88"	.020"	.551"	.472"	749.00	637.00
2124-E2 *	1.6-2"	B	.00020"	1.6" DIA	6"	3.88"	.020"	.551"	.472"	798.00	678.00
2124-E25 *	2-2.5"	C	.00020"	2.5" DIA	6"	4.48"	.020"	.689"	.571"	864.00	734.00
2124-E3 *	2.5-3"	C	.00020"	2.5" DIA	6"	4.48"	.020"	.689"	.571"	921.00	783.00
2124-E35 *	3-3.5"	C	.00020"	3.5" DIA	6"	4.48"	.020"	.689"	.571"	980.00	833.00
2124-E4 *	3.5-4"	C	.00020"	3.5" DIA	6"	4.48"	.020"	.689"	.571"	1043.00	887.00

setting rings are included



extension rods are included



*Supplied with manufacturer inspection certificate

THREE POINTS INTERNAL MICROMETERS



- .275-.5": graduation .0001"
- .5-4": graduation .0002"
- Ratchet stop
- Optional accessory: micrometer stand and clamp (part no. 6301 and 6301-2)



micrometer stand with clamp (optional)



3227-E035

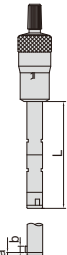

Type A
.275-.5", steel points



3227-E065

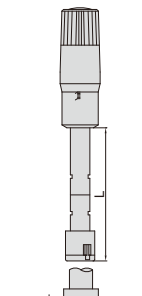

Type B
.5-2", carbide points



3227-E4

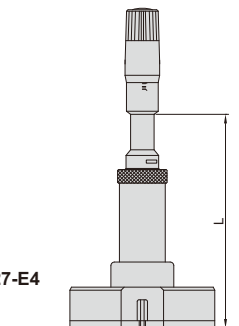

Type C
2-4", carbide points

Individual

Part No.	Range	Type	Accuracy	Setting ring (included)	Extension rod (included)	L	a	b	c	List Price (\$)	Sale Price (\$)
3227-E035 *	.275-.35"	A	.00015"	.275" DIA	4"	2.146"	.059"	.098"	—	497.00	422.00
3227-E0425 *	.35-.425"	A	.00015"	.35" DIA	4"	2.146"	.059"	.098"	—	497.00	422.00
3227-E05 *	.425-.5"	A	.00015"	.5" DIA	4"	2.146"	.059"	.098"	—	497.00	422.00
3227-E065 *	.5-.65"	B	.00015"	.65" DIA	6"	3.150"	.020"	.236"	.177"	376.00	320.00
3227-E08 *	.65-.8"	B	.00015"	.65" DIA	6"	3.150"	.020"	.236"	.177"	376.00	320.00
3227-E1 *	.8-1"	B	.00015"	1" DIA	6"	3.543"	.020"	.315"	.236"	527.00	448.00
3227-E112 *	1-1.2"	B	.00015"	1" DIA	6"	3.543"	.020"	.315"	.236"	527.00	448.00
3227-E16 *	1.2-1.6"	B	.00015"	1.6" DIA	6"	3.819"	.020"	.551"	.472"	568.00	483.00
3227-E2 *	1.6-2"	B	.00020"	1.6" DIA	6"	3.819"	.020"	.551"	.472"	659.00	560.00
3227-E25 *	2-2.5"	C	.00020"	2.5" DIA	6"	4.488"	.020"	.689"	.571"	715.00	608.00
3227-E3 *	2.5-3"	C	.00020"	2.5" DIA	6"	4.488"	.020"	.689"	.571"	766.00	651.00
3227-E35 *	3-3.5"	C	.00020"	3.5" DIA	6"	4.488"	.020"	.689"	.571"	801.00	681.00
3227-E4 *	3.5-4"	C	.00020"	3.5" DIA	6"	4.488"	.020"	.689"	.571"	833.00	708.00

setting rings are included



extension rods are included



Set

Part No.	Range	Micrometers included	Setting ring (included)	Extension rod (included)	List Price (\$)	Sale Price (\$)
3227-E053 *	.275-.5"	.275-.35", .35-.425", .425-.5"	.275" DIA, .35" DIA, .5" DIA	4"	1389.00	1181.00
3227-E082 *	.5-.8"	.5-.65", .65-.8"	.65" DIA	6"	699.00	594.00
3227-E24 *	.8-2"	.8-1", 1-1.2", 1.2-1.6", 1.6-2"	1" DIA, 1.6" DIA	6"	1995.00	1696.00
3227-E44 *	2-4"	2-2.5", 2.5-3", 3-3.5", 3.5-4"	2.5" DIA, 3.5" DIA	6"	2660.00	2261.00



3227-E24

*Supplied with manufacturer inspection certificate

TELESCOPING GAGE SET

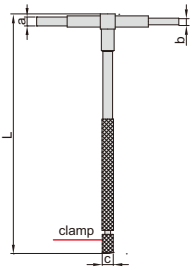

4206-1

- 6 gages per set
- For quick measurement of inside diameter of holes and width of slots
- Satin chrome finish

Range	L	a	b	c
5/16~1/2"	4.528"	.154" DIA	.114" DIA	.244" DIA
1/2~3/4"	4.528"	.209" DIA	.150" DIA	.244" DIA
3/4~1-1/4"	4.528"	.209" DIA	.150" DIA	.244" DIA
1-1/4~2-1/8"	5.394"	.299" DIA	.240" DIA	.283" DIA
2-1/8~3-1/2"	5.394"	.299" DIA	.240" DIA	.283" DIA
3-1/2~6"	5.394"	.299" DIA	.240" DIA	.283" DIA

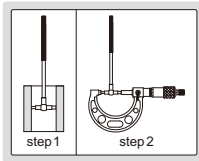

Part No.	Total range	Gages included	List Price (\$)	Sale Price (\$)
4206-1	5/16~6"	5/16~1/2", 1/2~3/4", 3/4~1-1/4", 1-1/4~2-1/8", 2-1/8~3-1/2", 3-1/2~6"	47.20	40.10

BORE GAGES

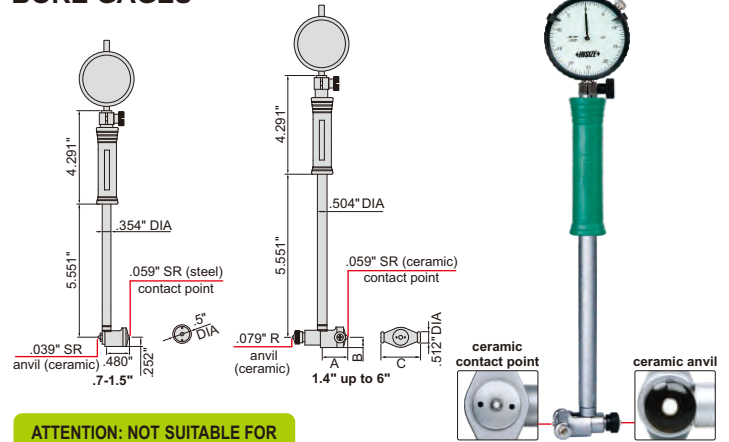

ATTENTION: NOT SUITABLE FOR .00005" OR .0001" DIAL INDICATORS

- Optional accessory: setting ring (part no. 6313), long handle (part no. 7351)

Range	A	B	C
1.4-2.4"	.866"	.354"	1.063"
2-6"	1.024"	.354"	1.378"

With dial indicator

Part No.	Range	Indicator	Accuracy	Repeatability	List Price (\$)	Sale Price (\$)
2323-15	.7-1.5"	dial indicator range .25" graduation	±.00075"	.00015"	210.00	179.00
2323-24	1.4-2.4"	dial indicator range .25" graduation	±.0009"	.00015"	192.00	163.00
2323-6	2-6"	dial indicator range .25" graduation	±.0009"	.00015"	202.00	172.00

BORE GAGE SETS

ATTENTION: NOT SUITABLE FOR .00005" OR .0001" DIAL INDICATORS

- Repeatability .00015"
- Dial indicator: range .25", graduation .0005"
- Optional accessory: setting ring (part no. 6313), long handle (part no. 7351)

packaging (part no. 2824-S3E)



Part No.	Range	Bore gages included	Accuracy	List Price (\$)	Sale Price (\$)
2824-S2E	1.4-6"	① 1.4-2" (dial indicator and handle are not included) ② 2-6"	1.4-2" ±.0009" 2-6" ±.0009"	231.00	196.00
2824-S3E	.7-6"	① .7-1.5" ② 1.4-2.4" (dial indicator is not included) ③ 2-6" (dial indicator is not included)	.7-1.5" ±.00075" 1.4-2.4" ±.0009" 2-6" ±.0009"	526.00	447.00



ELECTRONIC INDICATOR (STANDARD TYPE)

DATA OUTPUT INSPECTION CERTIFICATE TRACEABLE TO NIST



2112-10E

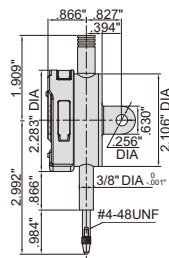

spindle lift knob is included



Part No.	Range	Resolution	List Price (\$)	Sale Price (\$)
2112-10E*	.5"/12.7mm	.0005"/0.01mm	138.00	117.00

*Supplied with manufacturer inspection certificate traceable to NIST

DIAL INDICATOR

INSIZE ISO17025 CERTIFICATE AVAILABLE AT EXTRA CHARGE (REFER TO BACK COVER)



2307-1

- Graduation .001"
- Meet ASME B89.1.10M-2001
- Lug back
- Supplied with limit pointers and bezel clamp
- Optional accessory: backs, contact points

INSPECTION CERTIFICATE TRACEABLE TO NIST

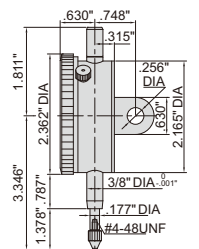

Part No.	Range	Accuracy		Range /rev	Dial reading	List Price (\$)	Sale Price (\$)
		First 2.5 rev	Overall				
2307-1*	1"	±.001"	±.002"	.1"	0-100	37.40	31.80

*Supplied with manufacturer inspection certificate traceable to NIST

DIAL TEST INDICATORS

JEWELLED BEARING
INSPECTION CERTIFICATE
 TRACEABLE TO NIST



2380-31

clamps are included

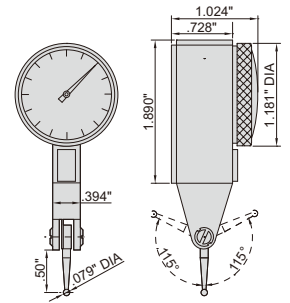
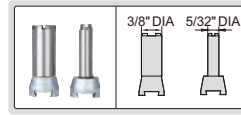

- Dial reading: 0-15-0
- Jeweled bearing
- Carbide contact point
- Two measuring directions
- Anti magnetic body
- Supplied with two clamps: 5/32" DIA and 3/8" DIA
- Optional accessory: styli

Part No.	Range	Graduation	Accuracy	List Price (\$)	Sale Price (\$)
2380-31*	.03"	.001"	±.001"	80.30	68.30
2380-35*	.03"	.0005"	±.0005"	100.00	85.00

*Supplied with manufacturer inspection certificate traceable to NIST

UNIVERSAL MAGNETIC STAND



6210-80E

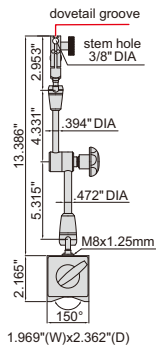

- For digital/dial indicators and dial test indicator
- With fine adjustment and dovetail groove

MAGNETIC STAND



6201-60

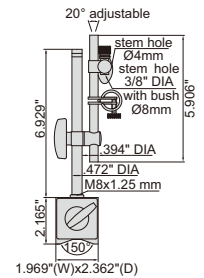

- Applicable holding stem: 3/8" DIA, Ø8mm, Ø4mm
- For electronic/dial indicators and dial test indicators

Part No.	Magnetic force	Applicable holding stem	List Price (\$)	Sale Price (\$)
6210-80E	176lbf	3/8" DIA	167.00	142.00

Part No.	Magnetic force	Remark	List Price (\$)	Sale Price (\$)
6201-60	132lbf	with fine adjustment	30.50	25.90

MACHINIST SQUARES WITH WIDE BASE (ECONOMIC TYPE)

ATTENTION: NO ANTI-RUST TREATMENT, NOT HARDENED

ATTENTION: LOW ACCURACY



4707-100

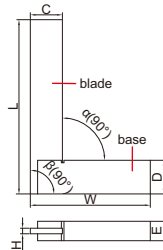

- DIN875 grade 2
- Made of carbon steel, no anti-rust treatment, not hardened

Part No.	Size (LxW)	Squareness		C	D	H	E	List Price (\$)	Sale Price (\$)
		Inside (α)	Outside (β)						
4707-100	3.9x2.8"	1.10mil	1.18mil	.748"	.748"	.118"	.472"	22.40	19.00
4707-150	6x4"	1.30mil	1.38mil	.984"	.984"	.118"	.630"	31.60	26.90
4707-200	8x5"	1.46mil	1.58mil	1.181"	1.260"	.157"	.630"	55.10	46.80
4707-300	12x8"	1.85mil	1.97mil	1.260"	1.260"	.157"	.748"	82.60	70.20

UNIVERSAL PROTRACTOR

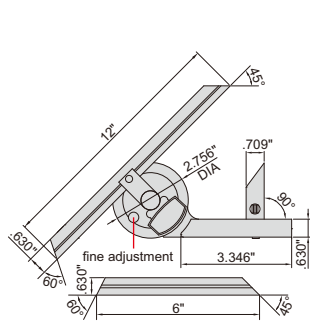

6" blade is included



2372-360

clamp for height gages (optional)

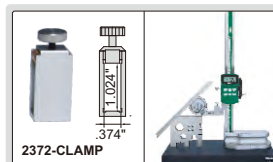

- Graduation 5', accuracy ±5'
- Parallax-free reading
- Made of stainless steel
- Optional accessory: clamp (part no. 2372-CLAMP), suitable for height gages 1156, 1351 and 1250

Part No.	Range	List Price (\$)	Sale Price (\$)
2372-360	0-360°	115.00	97.80

FEELER GAGE



4608-31

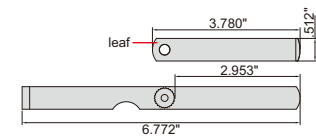

- .010" is made of brass, others are made of hardened alloy steel
- Each blade is marked with inch/metric size

Thickness of leaves included	Accuracy
.010" (brass)	±.00039"
.0015", .002"	±.0002"
.0025", .003", .004", .005", .006", .007"	±.00028"
.008", .009"	±.00035"
.010", .011"	±.00039"
.012", .013"	±.00047"
.014", .015"	±.00051"
.016", .017"	±.00055"
.018", .019"	±.00059"
.020", .021"	±.00067"
.022", .023"	±.00071"
.024", .025", .026"	±.00075"
.028"	±.00091"
.030"	±.00094"
.032", .035"	±.00102"

Part No.	Range	Quantity of Leaves	List Price (\$)	Sale Price (\$)
4608-31	.0015"~.035"	32	10.90	9.27

3-PIECE MEASURING TOOL SET

- Includes:
 - 1) Electronic caliper, range 0-6"/0-150mm, resolution .0005"/0.01mm (part no. 1108-150)
 - 2) Outside micrometer, range 0-1", graduation .0001" (part no. 3202-1)
 - 3) Steel rule, 6"/150mm (part no. 7110-150)



5003-1E

Part No.	List Price (\$)	Sale Price (\$)
5003-1E	109.00	92.70

2-PIECE MEASURING TOOL SET

- Includes:
 - 1) Electronic caliper, range 0-6"/0-150mm, resolution .0005"/0.01mm (part no. 1108-150)
 - 2) Electronic outside micrometer, range 0-1"/0-25mm, resolution .00005"/0.001mm (part no. 3109-25A)



5022

Part No.	List Price (\$)	Sale Price (\$)
5022	197.00	167.00

3-PIECE MEASURING TOOL SET

- Includes:
 - 1) Dial caliper, range 0-6", graduation .001" (part no. 1311-6)
 - 2) Outside micrometer, range 0-1", graduation .0001" (part no. 3202-1)
 - 3) Steel rule, 6"/150mm (part no. 7110-150)



5003-1

Part No.	List Price (\$)	Sale Price (\$)
5003-1	116.00	98.60

ELECTRONIC EDGE FINDERS

- Accuracy .0002"
- The shank is electrically conducted to the metal workpiece through the chuck and table, when the ball touches the workpiece
- Not suitable for rotary use
- Hardened shank and contact ball

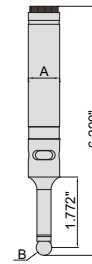

6566-2E

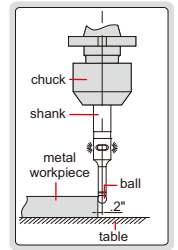

Part No.	Shank (A)	Contact ball (B)	Battery	List Price (\$)	Sale Price (\$)
6566-2E	3/4" DIA	.4" DIA	23AE, 12Vx1 pc	138.00	117.00

VISION MEASURING SYSTEMS

SPECIFICATION

Part No.	ISD-V150A	ISD-V250A	ISD-V300A
List Price (\$)	12900.00	13250.00	15500.00
Sale Price (\$)	10965.00	11263.00	13175.00
Measuring range (X*Y*Z)	6x4x8"	10x6x8"	12x8x8"
Stage size	13.94x8.98"	17.72x11.02"	19.69x12.99"
Glass stage size	8.27x6.30"	12.05x7.72"	13.78x9.84"
Resolution of X/Y/Z axis	.00002"		
Accuracy of X/Y axis	≤(98.4+10L)μin (L is the measuring length in inch)		
Repeatability of X/Y axis	.00008"		
Objective	0.7X~4.5X (zoom)		
Working distance	3.62"		
Magnification	33X~195X (on 19" monitor)		
Camera	1/3" color CCD, 0.3M pixel		
Illumination	surface and contour with adjustable LED		
Max. height of workpiece	6.30"		
Max. weight of workpiece	44lb		
Operation system	Windows 7/8/10		
Drive method	manual		
Power supply	110/220V, 50/60Hz		
Dimension (L*W*H)	22.05x21.26x33.46"	29.92x23.62x35.43"	29.92x23.62x35.43"
Weight	220lb	264lb	308lb



ISD-V250A

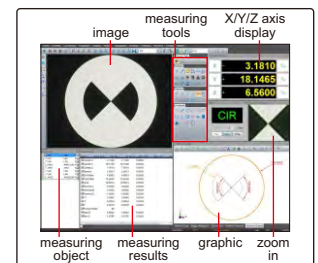

computer is included



software CD (included)

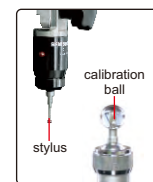

probe (optional), includes Ø2mm/.079" DIA and Ø3mm/.118" DIA styli, Ø25mm/.984" calibration ball, measuring accuracy is .0004"



lens with coaxial light (optional, must be installed in factory)

STANDARD DELIVERY

Main unit	1 pc
Computer	1 pc
Calibration glass chart	1 pc
Clay	1 pc
Foot switch	1 pc
Anti-dust cover	1 pc

OPTIONAL ACCESSORY

0.5X auxiliary objective	Part No. ISD-V-OB05X Working distance: 6.89" Magnification: 16.5~97.5X (on 19" monitor)
2X auxiliary objective	Part No. ISD-V-OB2X Working distance: 1.42" Magnification: 66~390X (on 19" monitor)
Probe	Part No. ISD-V-PROBE includes Ø2mm/.079" DIA and Ø3mm/.118" DIA styli, Ø25mm/.984" calibration ball

CNC VISION MEASURING SYSTEMS



- Automatic edge-detection, focus, measuring, contour scanning, calibration, etc.
- Servo motors for X, Y, Z axis
- SPC function for large quantity measurement

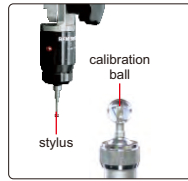

probe (optional), includes Ø2mm/.079" DIA and Ø3mm/.118" DIA styli, Ø25mm/.984" calibration ball, measuring accuracy is .0004"

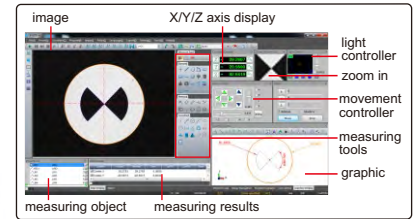
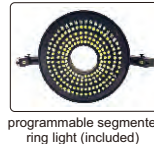

computer is included

controller

ISD-V220CNCA-U

SPECIFICATION

Part No.	ISD-V220CNCA-U**	ISD-V270CNCA-U**	ISD-V370CNCA-U**
List Price (\$)	30750.00	33250.00	40900.00
Sale Price (\$)	26138.00	28263.00	34765.00
Measuring range (X*Y*Z)	8.66×4.72×5.90"	10.63×6.69×5.90"	14.57×10.63×5.90"
Stage size	17.72×11.02"	19.69×12.99"	23.86×18.35"
Glass stage size	12.05×7.72"	13.78×9.84"	17.72×13.78"
Resolution of X/Y/Z axis	.00002"		
Accuracy of X/Y axis	≤(98.4+10L)µin (L is the measuring length in inch)		
Repeatability of X/Y axis	.00008"		
Objective	0.7X~4.5X (zoom)		
Working distance	3.62"		
Magnification	20X~128X (on 19.5" monitor)		
Camera	1/2" color CCD, 0.4M pixel		
Illumination	surface	coaxial light, programmable segmented ring light	
	contour	adjustable LED	
View field (diagonal length)	.07~.44"		
Max. height of workpiece	6.30"		
Max. weight of workpiece	66lb		
Operation system	Windows 7/8/10		
Drive method	Automatic		
Power supply	110V, 50/60Hz**		
Dimension (L*W*H)	29.92×23.62×35.43"	29.92×23.62×35.43"	38.19×26.38×37.01"
Weight	322lb	370lb	586lb

STANDARD DELIVERY

Main unit	1 pc
Computer	1 pc
Controller	1 pc
Calibration glass chart	1 pc
Clay	1 pc
Anti-dust cover	1 pc



software CD (included)

OPTIONAL ACCESSORY

0.5X auxiliary objective	Part No. ISD-V-OB05X Working distance: 6.89" Magnification: 10~64X (on 19.5" monitor)
2X auxiliary objective	Part No. ISD-V-OB2X Working distance: 1.42" Magnification: 66~390X (on 19.5" monitor)
Probe	Part No. ISD-V-PROBE includes Ø2mm/.079" DIA and Ø3mm/.118" DIA styli, Ø25mm/.984" calibration ball

ELECTRONIC LEVEL AND SLOPE METER

BACKLIGHT

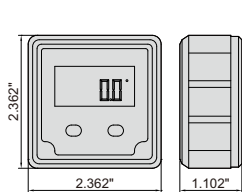

2170-1

MAGNETIC BOTTOM ABSOLUTE LEVEL

WORKING TEMPERATURE 23°F~122°F

DISPLAY FLIPS OVER WHEN THE BOTTOM FACES UP

- Used as level and slope meter
- Aluminum frame
- Magnetic bottom
- The display flips over when the bottom faces up
- The backlight is on automatically when in use, and automatically off in 15 minutes after use
- The sea level is permanently set inside the chip, zero setting is not needed when battery is replaced
- Buttons: ON/OFF, ZERO, absolute and incremental measurement
- One AAA battery, automatic power off in 5 minutes

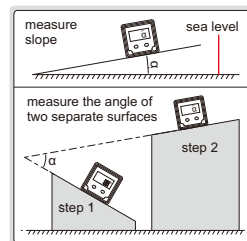

Part No.	Range	Resolution	Accuracy	List Price (\$)	Sale Price (\$)
2170-1	4x90°	0.1° (= .021in/ft)	at 0° and 90°: ±0.1°; others: ±0.2°	101.00	85.90

ELECTRONIC LEVEL AND SLOPE METER

BACKLIGHT

IP54 WATERPROOF

ABSOLUTE LEVEL

WORKING TEMPERATURE 23°F~122°F

BUZZER ALARM AT 0° AND 90°



2179-360

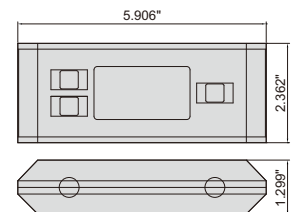

- IP54 dust/waterproof
- Used as level and slope meter
- Aluminum frame
- Magnetic bottom with V-groove for shafts
- The sea level is permanently set inside the chip, zero setting is not needed when battery is replaced
- Buttons: ON/OFF, absolute and incremental measurement, keep the reading, buzzer alarm, unit (mm/m, %, in/ft), conversion, backlight
- Two AAA batteries, automatic power off

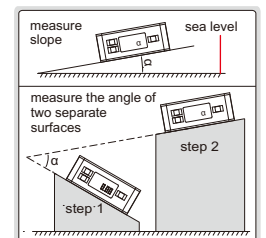

Part No.	Range	Resolution	Accuracy	List Price (\$)	Sale Price (\$)
2179-360	0-360° (90°x4)	0.05° (= .00625in/ft)	at 0° and 90°: ±0.1°; others: ±0.2°	172.00	146.00

MANUAL ROCKWELL HARDNESS TESTER
PART NO. ISH-R150



SPECIFICATION

List Price (\$)	3060.00
Sale Price (\$)	2601.00
Hardness scale	HRA, HRB, HRC, HRD, HRF, HRG
Preliminary test force	98N/10kgf
Test force	588N/60kgf, 980N/100kgf, 1471N/150kgf
Display	analogue
Stage elevation	manual
Load control	manual
Min. reading	0.5HR
Max. workpiece height	6.69"
Max. workpiece depth	6.50" (from the center of indenter)
Dimension	20.47×6.30×27.56"
Weight	132lb

STANDARD DELIVERY

Main unit	1 pc
2.36" DIA flat anvil	1 pc
5.91" DIA flat anvil	1 pc
V-type anvil	1 pc
Diamond indenter	1 pc
1/16" DIA carbide ball indenter	1 pc
Hardness test block HRC20-30	1 pc
Hardness test block HRC60-65	1 pc
Hardness test block HRB88-95	1 pc
Anti-dust cover	1 pc

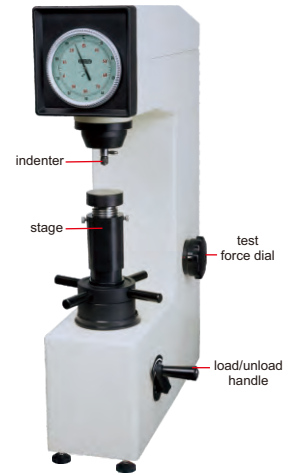

OPTIONAL ACCESSORY

Hardness test block HRC20-30	ISH-BHRC1
Hardness test block HRC60-65	ISH-BHRC3
Hardness test block HRB88-95	ISH-BHRB
Small V-type anvil	ISH-SMALL ANVIL

DIGITAL MEASURING MICROSCOPE (WITH DISPLAY)

TAKE PICTURES

MEASUREMENT

BUILT-IN SOFTWARE WITHOUT COMPUTER

ATTENTION: PLEASE MAKE CONFOCAL ADJUSTMENT AFTER CHANGING CAMERA ADAPTERS OR AUXILIARY OBJECTIVES

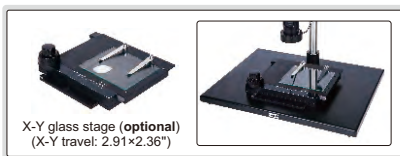

- 1080P high-definition image
- Built-in software without computer, operation by mouse
- Take pictures, saved to USB flash disk
- Measurement results can be sent to Excel
- Automatic white balance and exposure
- Brightness, contrast ratio, gain are adjustable

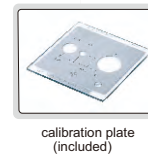
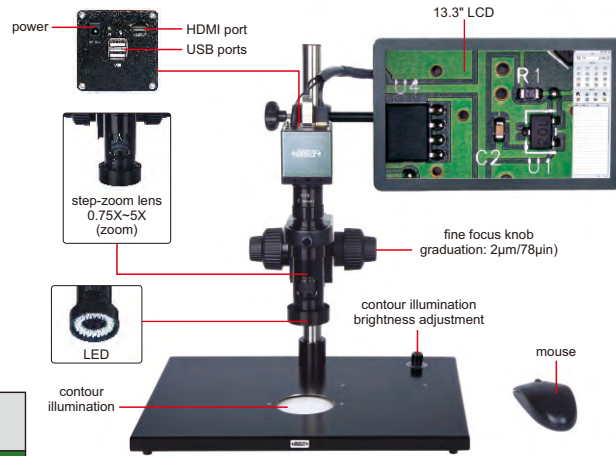

ISM-DL301-U (with contour illumination)

SPECIFICATION

Part No.	ISM-DL301-U** (with contour illumination)
List Price (\$)	3467.00
Sale Price (\$)	2947.00
Magnification	15X~100X
Sensor	1/2" CMOS
Pixel	2M
Resolution	1920×1080
Frame rate	60fps
Output	HDMI
Power supply	power adapter and 110V, 50/60Hz**
Dimension (L×W×H)	22.44×11.81×16.93"
Weight	14.44lb

Part No.	List Price (\$)	Sale Price (\$)
ISM-DL-STAGE	229.00	195.00

MEASURING ACCURACY

Objective magnification	Image magnification	Measuring accuracy*
0.75X	15X	±.00031"
1X	20X	±.00028"
1.5X	30X	±.00024"
2X	40X	±.00024"
2.5X	50X	±.00024"
3X	60X	±.00020"
3.5X	70X	±.00020"
4X	80X	±.00016"
4.5X	90X	±.00016"
5X	100X	±.00016"

*When measuring the contour of workpieces, please select ISM-DL301-U for high accuracy.

STANDARD DELIVERY

Main unit	1 pc
0.5X camera adapter	1 pc
1X auxiliary objective	1 pc
Calibration plate	1 pc
16G USB flash disk	1 pc
White/black plate	1 pc
Mouse	1 pc
HDMI cable	1 pc
Power adapter	2 pcs

OPTIONAL ACCESSORY

1X camera adapter	ISM-DL-CA1X
2X auxiliary objective	ISM-DL-OB2X
X-Y glass stage (travel: 2.91×2.36")	ISM-DL-STAGE
X-Y metal stage	ISM-DL-STAGE1
LED auxiliary illumination	ISM-DL-LED
Coaxial light illumination	ISM-DL-COAXIAL
Auxiliary objective	see details

MAGNIFICATION, FOCUS DISTANCE AND VIEW FIELD

Auxiliary Objective	Specification	Camera adapter	
		0.5X (included)	1X (optional)
1X (included)	Magnification	15~100X	30~200X
	Focus distance	2.76±.08"	2.76±.08"
	View filed	.63×.43"~.1×.06"	.31×.21"~.05×.03"
2X (optional)	Magnification	30~200X	60~400X
	Focus distance	1.14±.08"	1.14±.08"
	View filed	.31×.21"~.05×.03"	.15×.11"~.024×.016"

AUTO FOCUS DIGITAL MICROSCOPE (WITH DISPLAY) PART NO. 5303-AF103

AUTO FOCUS

TAKE PICTURES AND VIDEOS

- 1080P high-definition image
- Auto focus camera
- Take pictures and videos, saved to USB flash disk
- Picture review, picture compare
- Automatic exposure and white balance
- Brightness, contrast ratio, gain are adjustable
- Display cross hair (blue/green/red/yellow/black/brown colors)

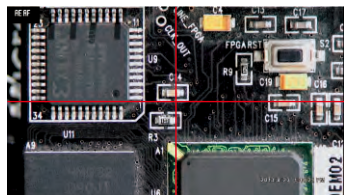

display cross hair
(blue/green/red/yellow/black/brown colors)



X-Y glass stage (optional)
(X-Y travel: 2.91×2.36")

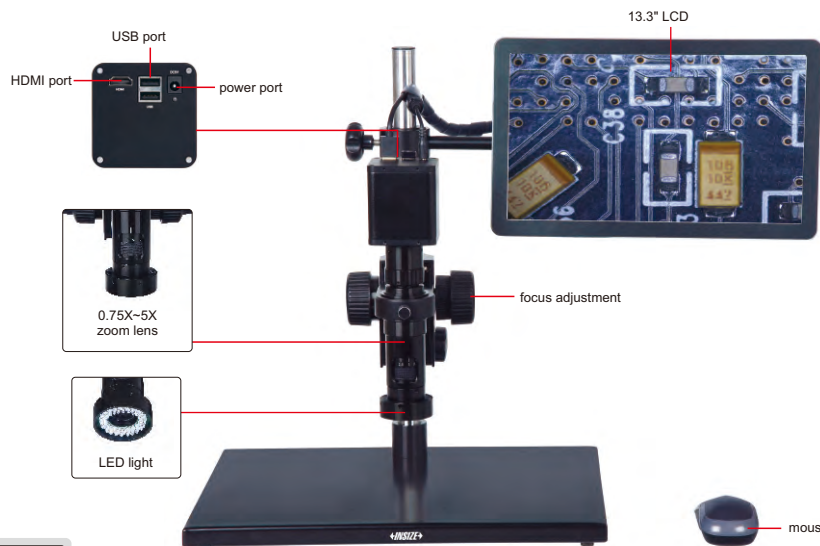

1X auxiliary objective
(included)



0.5X camera adapter
(included)



1X camera adapter
(optional)



16G USB flash disk
(included)



2X auxiliary objective
(optional)

SPECIFICATION

List Price (\$)	3253.00
Sale Price (\$)	2765.00
Magnification	20X~123X
Sensor	1/2.8" CMOS
Pixel	2M
Resolution	1920×1080
Frame rate	60fps
Output	HDMI
Power supply	power adapter
Dimension (L×W×H)	22.44×11.81×16.93"
Weigh	14.33lb

MAGNIFICATION, FOCUS DISTANCE AND VIEW FIELD

Auxiliary Objective	Specification	Camera adapter	
		0.5X (included)	1X (optional)
1X (included)	Magnification	20~123X	40~246X
	Focus distance	1.89~3.31"	1.89~3.31"
	View filed	.51×.28~.09×.04"	.25×.14~.04×.02"
2X (optional)	Magnification	40~246X	80~492X
	Focus distance	.94~1.65"	.94~1.65"
	View filed	.26×.14~.04×.02"	.13×.07~.02×.01"

AUTO FOCUS DISTANCE

Zoom objective scale	0.75X	1X	1.5X	2X	2.5X
Auto focus distance	1.89~3.31"	1.97~3.07"	2.17~2.87"	2.44~2.80"	2.56~2.76"

Zoom objective scale	3X	3.5X	4X	4.5X	5X
Auto focus distance	2.60~2.76"	2.64~2.76"	2.68~2.76"	2.68~2.76"	2.68~2.76"

STANDARD DELIVERY

Main unit	1 pc
0.5X camera adapter	1 pc
1X auxiliary objective	1 pc
16G USB flash disk	1 pc
White/black plate	1 pc
Mouse	1 pc
HDMI cable	1 pc
Power adpter	2 pcs

OPTIONAL ACCESSORY

1X camera adapter	ISM-DL-CA1X
2X auxiliary objective	ISM-DL-OB2X
X-Y glass stage (travel: 2.91×2.36")	ISM-DL-STAGE
X-Y metal stage	ISM-DL-STAGE1
LED auxiliary illumination	ISM-DL-LED
Coaxial light illumination	ISM-DL-COAXIAL
Auxiliary objective	see details

**3D MOTORIZED ROTATION MICROSCOPE (WITH DISPLAY)
PART NO. 5301-D400**

SUITABLE TO CHECK CONVEX OBJECTS AND WALL OF HOLE

TAKE PICTURES AND VIDEOS

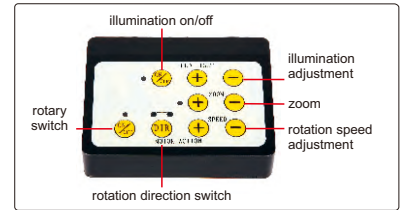
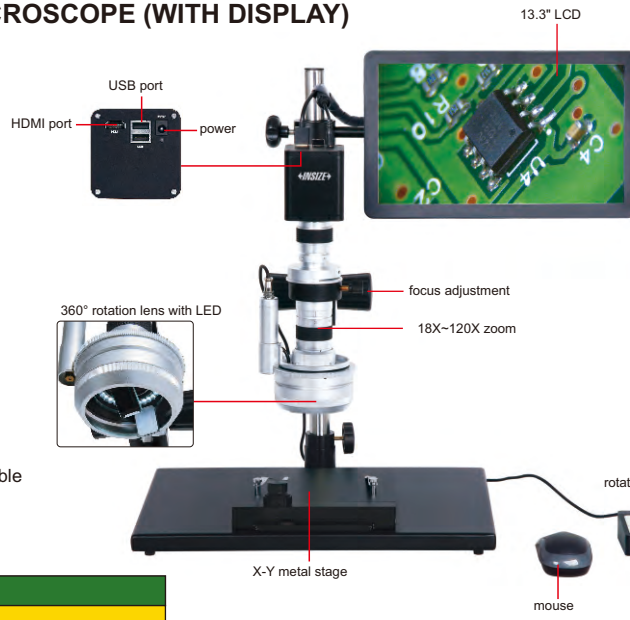
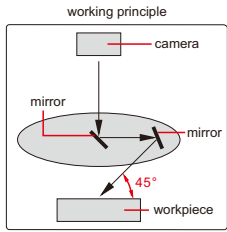

- 1080P high-definition 3D image
- Take pictures and videos, save to USB flash disk
- Automatic white balance and exposure
- Brightness, contrast ratio and gain are adjustable

SPECIFICATION

List Price (\$)	8179.00
Sale Price (\$)	6952.00
Magnification	18X~120X
View field	.14x.08~.94x.57"
Focus distance	1.02"
View angle	45°
Sensor	1/2.8" CMOS
Pixel	2M
Resolution	1920×1080
Frame rate	60fps
Output	HDMI
Rotation speed	2~5RPM
Power supply	110/220V, 50/60Hz
Dimension (L×W×H)	22.44×11.81×16.93"
Weight	22.05lb

STANDARD DELIVERY

Main unit	1 pc
Rotation controller	1 pc
X-Y metal stage	1 pc
16G USB flash disk	1 pc
White/black plate	1 pc
Mouse	1 pc
Power adapter	2 pcs

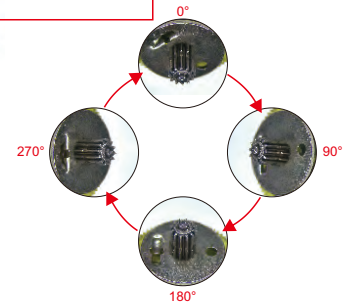

**DIGITAL MEASURING MICROSCOPE
PART NO. ISM-PM200SA**

- Can take pictures and videos
- Supplied with software

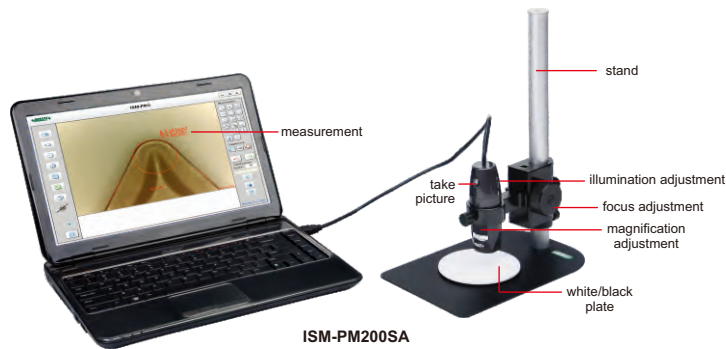

computer is optional



SPECIFICATION

List Price (\$)	411.00
Sale Price (\$)	349.00
Magnification	10X~200X
Focus distance	short focus distance
Stand	standard
Focus support	included
Calibration rule	graduation 0.1mm/.004" and 1mm/.039"
Pixel	2M (resolution: 1600×1200)
Illumination	built-in adjustable LED
Power supply	USB 2.0 cable (voltage required: 5±0.1V)

filter (optional)



OPTIONAL ACCESSORY

Green filter	ISM-PM-GREEN
Yellow filter	ISM-PM-YELLOW
Blue filter	ISM-PM-BLUE

MAGNIFICATION, FOCUS DISTANCE, VIEW FIELD AND ACCURACY

Magnification	Focus distance	View field	Accuracy
50X	.83"	.32×.25"	1.2mil
100X	.51"	.15×.12"	0.6mil
150X	.63"	.10×.08"	0.4mil
200X	.75"	.07×.06"	0.3mil

WiFi DIGITAL MEASURING MICROSCOPE PART NO. ISM-WF200

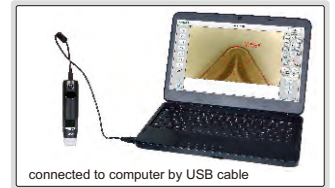
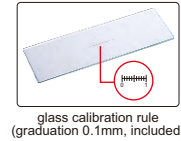
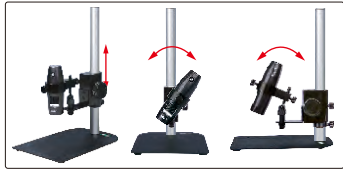

- Maximum working distance is 200" under WiFi mode
- Can be connected to multiple iPads, Android devices or computers at the same time under WiFi mode
- Take pictures and videos
- Supplied with software

SPECIFICATION

List Price (\$)	411.00
Sale Price (\$)	349.00
Magnification	10X~200X
Pixel	1.3M (resolution: 1280x1024)
Illumination	built-in adjustable LED
Power supply	built-in rechargeable battery

Part No.	List Price (\$)	Sale Price (\$)
ISM-WSTD	139.00	118.00

STANDARD DELIVERY

Microscope	1 pc
Base support	1 pc
Focus support ring for 80X/150X	1 pc
Focus support ring for 60X/200X	1 pc
Glass calibration rule (graduation 0.1mm)	1 pc
Plastic calibration rule (graduation 1mm)	1 pc
USB cable and software	1 pc
AC/DC adapter	1 pc

MAGNIFICATION, FOCUS DISTANCE, VIEW FIELD AND ACCURACY

Magnification	Focus distance	View field	Accuracy
50X	.83"	.32x.25"	1.2mil
100X	.51"	.15x.12"	0.6mil
150X	.63"	.10x.08"	0.4mil
200X	.75"	.07x.06"	0.3mil

OPTIONAL ACCESSORY

Stand	ISM-WSTD
Green filter	ISM-PM-GREEN
Yellow filter	ISM-PM-YELLOW
Blue filter	ISM-PM-BLUE

1 Software ISM-PAD (for iPad by WiFi)

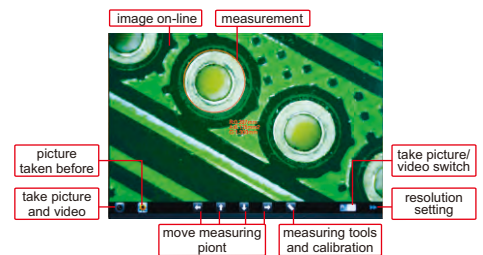

2 Software ISM-APK (for Android devices by WiFi)

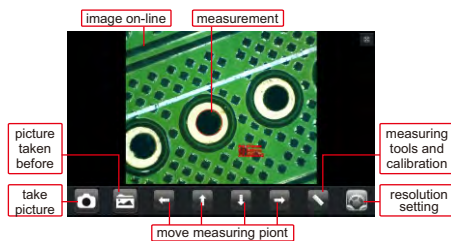

3 Software ISM-WF Partner (for computer by WiFi)

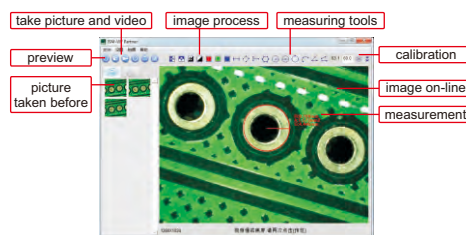

4 Software ISM-PRO (for computer by USB cable)

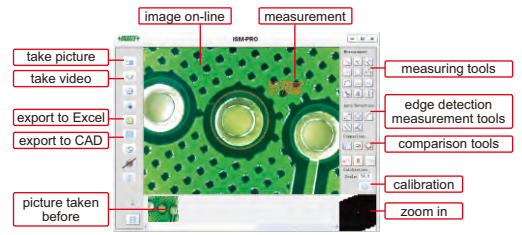

ROUGHNESS TESTER PART NO. ISR-C003



- Unit: μm , μin
- Automatic power off

STANDARD DELIVERY

Main unit	1 pc
Calibration block	1 pc
AC/DC adapter	1 pc

SPECIFICATION

List Price (\$)	1787.00	
Sale Price (\$)	1519.00	
Parameters	Ra, Rz, Rq, Rt	
Range	Ra, Rq: 2~590 μin Rz, Rt: 4~1968 μin	
Accuracy	$\pm 10\%$	
Resolution (Ra)	0.01 μin	
Probe	type	piezoelectric
	stylus radius/angle	393 $\mu\text{in}/90^\circ$
	stylus material	diamond
Measuring force	.012ozf	
Measuring unit	$\mu\text{in}/\mu\text{m}$	
Cut off	.01/.03/.1"	
Evaluation length	.05" for cut off .01"	
	.15" for cut off .03"	
	.2" for cut off .1"	
Traverse speed	.03"/s	
Power	built-in rechargeable battery	
Dimension (L×W×H)	4.17×2.75×.94"	
Weight	.44lb	

**ROUGHNESS TESTER (SEPARABLE TYPE)
PART NO. ISR-C300**

- Roughness tester can be operated by mobile phones (only android system) or computers
- Data can be sent to Excel by connecting with computers via bluetooth or USB cable
- Support bluetooth printer
- 22 roughness parameters
- Meet ISO, DIN, ANSI, JIS standards
- Display roughness values, profile and curve
- Memory of maximum 100 data and waveform
- Built-in lithium battery, working time more than 50 hours
- Touch screen
- Automatic power off

CAN BE OPERATED BY COMPUTER OR MOBILE PHONE

DATA OUTPUT

BLUETOOTH

TOUCH SCREEN

bluetooth printer (optional)

probe and main unit can be combined together



roughness tester screen display

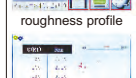
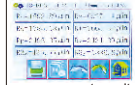

connect mobile phone via bluetooth (only android system)



operate roughness tester by mobile phone, display roughness values, profile and curve

connect computer via USB cable (software is included)

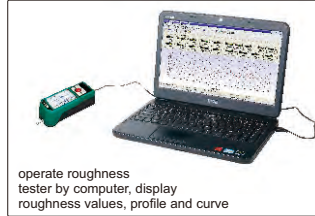

operate roughness tester by computer, display roughness values, profile and curve

magnetic stand adapter (included)



.315" DIA

can be installed on magnetic stands

height gage adapter (optional)



.345×.354"

can be installed on height gages

NOTE: Please confirm whether the adapter can fit your height gages. When using INSIZE height gages, please use the dial test indicator holder of height gages

data can be output to Excel by connecting computer via bluetooth or USB cable



adjustable stand (included)



height is adjustable (1.575")

probe support (optional)

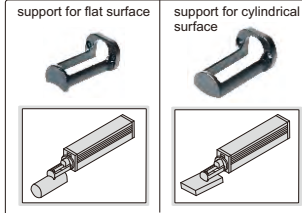

support for flat surface

support for cylindrical surface

optional probes

extension rod (optional), code ISR-C002-ER

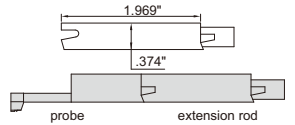

probe extension rod

small hole probe (optional), code ISR-C002-PROBE

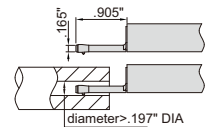

diameter>.197" DIA

tiny hole probe (optional), code ISR-C002-SBP

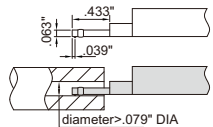

diameter>.079" DIA

curved surface probe (optional), code ISR-C002-SUR

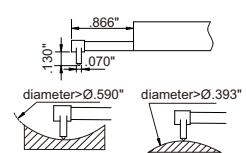

diameter>Ø.590" diameter>Ø.393"

deep groove probe (optional), code ISR-C002-DGP

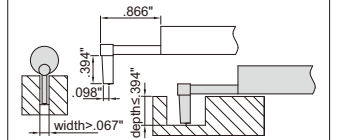

width>.067" depth>.394"

SPECIFICATION

List Price (\$)	2428.00
Sale Price (\$)	2064.00
Parameters	Ra, Rz, Rq, Rv, Rp, Rs, R3z, R3y, Rt, Rc, Rz (JIS), Rk, Rku, Rsm, Rpc, Rpk, Rvk, Rsk, Mr1, Mr2, Ry, Rmax
Range	X axis .689" Z axis 12598µin(-6299µin~6299µin)
Accuracy	±10%
Resolution (Ra)	0.01µin
Probe	type inductive stylus radius/angle 196µin/90° stylus material diamond
Measuring force	.01ozf
Measuring unit	µm/µin
Cut off	.01/.03/.1"
Number of cut-offs	1 to 5
Traverse speed	.005"/s, .02"/s, .04"/s
Memory	100 measurement results
Output	USB and bluetooth
Power	built-in rechargeable battery
Dimension (L×W×H)	6.22×2.52×2.05"
Weight	.89lb

STANDARD DELIVERY

Main unit	1pc
Standard probe	1pc
Calibration block and support	1pc of each
Connecting cable (long and short)	1pc of each
Magnetic stand adapter	1pc
Adjustable stand	1pc
Touch pen	1pc
USB cable and software	1pc
AC/DC adapter	1pc

STANDARD DELIVERY

Extension rod	ISR-C002-ER
Small hole probe	ISR-C002-PROBE
Tiny hole probe	ISR-C002-SBP
Deep groove probe	ISR-C002-DGP
Curved surface probe	ISR-C002-SUR
Bluetooth printer	ISR-C002-PRINTER
Height gage adapter	ISR-C300-LB1
Bluetooth receiver	ISR-C300-RECEIVER
Support for flat surface	ISR-C300-COVER1
Support for cylindrical surface	ISR-C300-COVER2

INSIZE USA

Add: 3492 Diversified Drive
Loganville, GA 30052
Tel: 470-240-2520
Fax: 470-448-4771
E-mail: info@insizeus.com

Connect with us on:



Distributed by: